

Thank you for choosing the **One-Click™ Cleaner MPO ESD**. The **One-Click™ Cleaner MPO ESD** is a high-performance device designed for cleaning the ferrule end faces of MPO connectors. Carefully read this handbook before using this device.

## 1. Safety precautions

	Though our device is deemed safe, improper usage or handling can still inflict injury to others.
	One-Click™ Cleaner MPO ESD is designed to clean MPO connectors. Fujikura is not liable for damage caused in attempt to apply this device to other applications.

## 2. Notes on usage



- Do not attempt to disassemble as this can cause damage to the device and void warranty.
- Do not re-use cleaning cloth as this will eliminate its cleaning ability.
- Do not touch the cleaning cloth as this will cause contamination.
- Do not pull the cleaning cloth, use only the device body.
- Do not use this cleaner when the cloth is empty, as this can cause damage to the connector.

## 3. Notes on storage for extended periods

- Do not expose device to direct sunlight, high temperature or high humidity.
- The cover on the guide cap should be closed at all times when device is not in use.

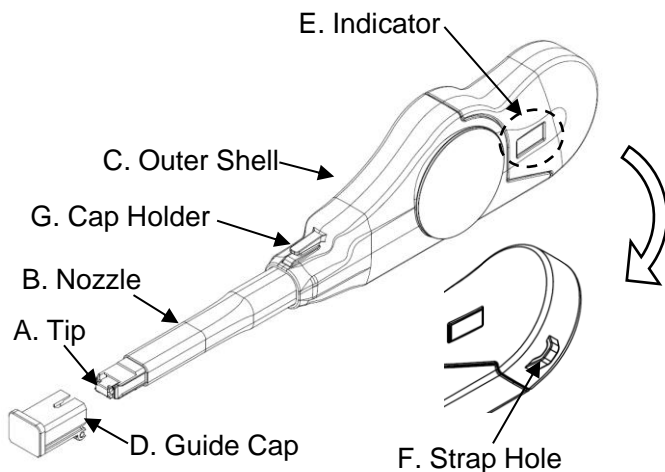
## 4. Device construction



	View of Indicator	
Full		Cloth (White)
Little		Clear
Empty		Clear

Identification of remaining cloth

No.	Part Name	Function
A	Tip	Aligns the cleaning cloth to the connector end face when cleaning through the connector adapter.
B	Nozzle	Allows the tip to reach connector adapters in patch panels.
C	Outer Shell	Houses cleaning cloth and pushed forward to clean the connector.
D	Guide Cap	Acts as a dust cap and is used as an adapter to cleaning connectors on jumpers.
E	Indicator	Provides indication of remaining cleaning cloth.
F	Strap Hole	Can be used to attach a strap to the cleaner (strap not included).
G	Cap Holder	Used to store the guide cap when not in use.

## 5. Applications(One-Click™ Cleaner MPO ESD)

### <Connector inside adapter>

### <Connector on jumper>

1. Remove Guide Cap from the device

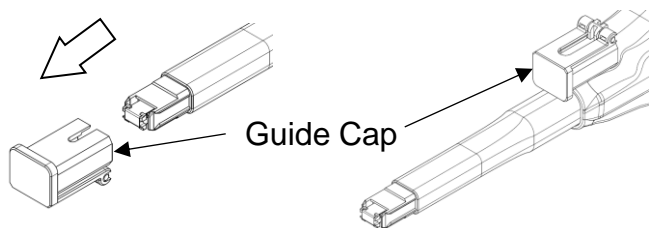

The Guide Cap can be attached Cap Holder.

1. Open the Cover on the Guide Cap

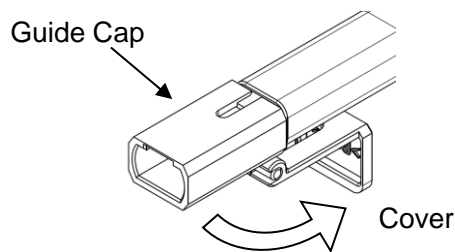

2. Insert tip of cleaner into MPO Adapter

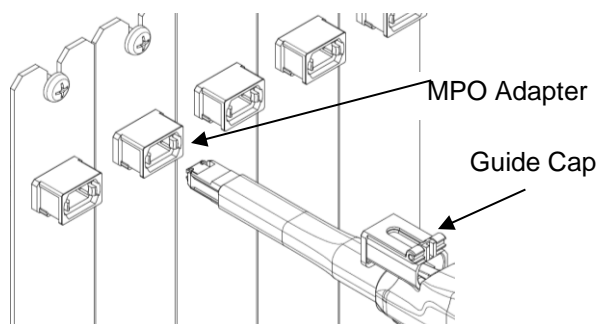

2. Insert MPO Plug into the Guide Cap.

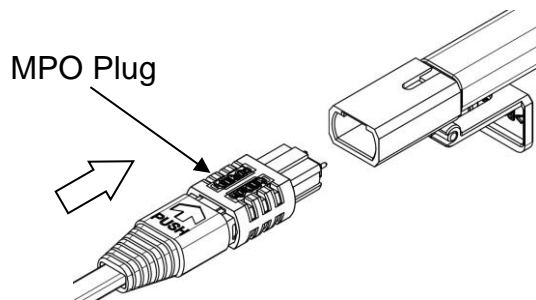

3. Push the Outer Shell to start cleaning the MPO connector end face. An audible “click” sound indicates end of cleaning process. Close the cover after use.

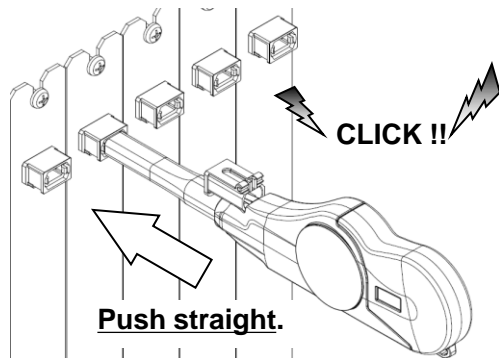

Be careful not to slant the One-Click™ Cleaner MPO ESD while inserting into the adapter.

Do not overly exert force during insertion as this may cause damage to both the connector and the One-Click™ Cleaner MPO ESD.

※If pushing Outer Shell is inhibited, remove the cleaner from the connector and verify that there is no large debris inhibiting the cleaning process.

3. Push the Outer Shell to initiate the cleaning the MPO connector end face. An audible “click” sound indicates end of cleaning process. Close the cover after use.

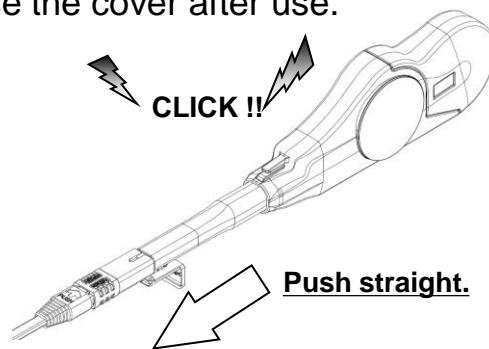

Be careful not to slant connector while inserting into the Guide cap.

Do not overly exert force during insertion as this may cause damage to both the connector and the One-Click™ Cleaner MPO.

※If pushing Outer Shell is inhibited, remove the cleaner from the connector and verify that there is no large debris inhibiting the cleaning process.

## 6. Contact us

<https://www.optic-product.fujikura.com/optical-components/contact/>